

# SURFACE MOUNT SCHOTTKY BARRIER RECTIFIER SS32F THRU SS3200F

## Features

1. The plastic package carries Underwriters Laboratory Flammability Classification 94V-0
2. For surface mounted applications
3. Metal silicon junction, majority carrier conduction
4. Low power loss, high efficiency
5. Built-in strain relief, ideal for automated placement
6. High forward surge current capability
7. High temperature soldering guaranteed:  
260 °C/10 seconds at terminals

## Mechanical Data

**Case :** JEDEC SMAF molded plastic body  
**Terminals :** Solderable per MIL-STD-750, Method 2026  
**Polarity :** Color band denotes cathode end  
**Mounting Position :** Any  
**Weight :** 0.0018 ounce, 0.064 grams

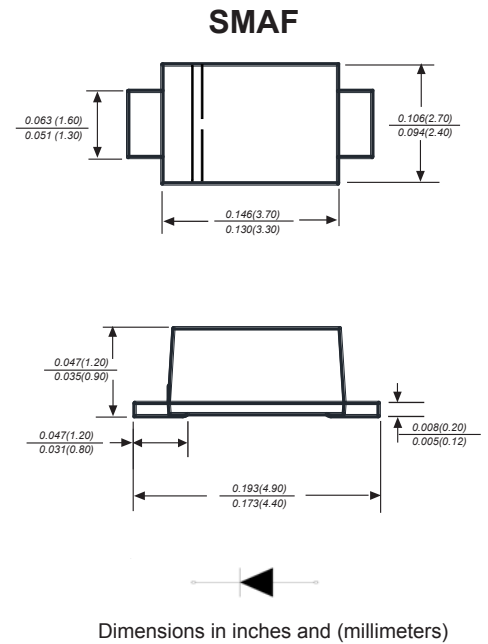

## Maximum Ratings And Electrical Characteristics

Ratings at 25°C ambient temperature unless otherwise specified.

Single phase half-wave 60Hz, resistive or inductive load, for capacitive load current derate by 20%.

Parameter	SYMBOLS	SS32F	SS33F	SS34F	SS35F	SS36F	SS38F	SS310F	SS3150F	SS3200F	UNITS	
		SS32F	SS33F	SS34F	SS35F	SS36F	SS38F	SS310F	SS3150F	SS3200F		
Maximum repetitive peak reverse voltage	$V_{RRM}$	20	30	40	50	60	80	100	150	200	V	
Maximum RMS voltage	$V_{RMS}$	14	21	28	35	42	56	70	105	140	V	
Maximum DC blocking voltage	$V_{DC}$	20	30	40	50	60	80	100	150	200	V	
Maximum average forward rectified current at TL (see fig.1)	$I_{(AV)}$	3.0									A	
Peak forward surge current 8.3ms single half sine-wave superimposed on rated load (JEDEC Method)	$I_{FSM}$	80									A	
Maximum instantaneous forward voltage at 3.0A	$V_F$	0.55			0.70		0.85		0.95		V	
Maximum DC reverse current at rated DC blocking voltage	$I_R$	0.5							0.2		mA	
		20.0			10		2.0					
Typical junction capacitance (NOTE 1)	$C_J$	500			300						pF	
Typical thermal resistance (NOTE 2)	$R_{\theta JA}$	55.0									°C/W	
Operating junction temperature range	$T_J$	-50 to +125					-50 to +150					°C
Storage temperature range	$T_{STG}$	-50 to +150									°C	

**Note:** 1. Measured at 1MHz and applied reverse voltage of 4.0V D.C.  
 2. P.C.B. mounted with 0.2x0.2" (5.0x5.0mm) copper pad areas

# SURFACE MOUNT SCHOTTKY BARRIER RECTIFIER SS32F THRU SS3200F

## Typical Characteristics

AVERAGE FORWARD RECTIFIED CURRENT, AMPERES

FIG. 1- FORWARD CURRENT DERATING CURVE

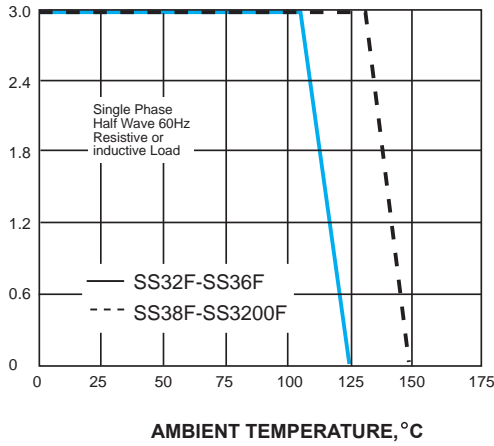

PEAK FORWARD SURGE CURRENT, AMPERES

FIG. 2-MAXIMUM NON-REPETITIVE PEAK FORWARD SURGE CURRENT

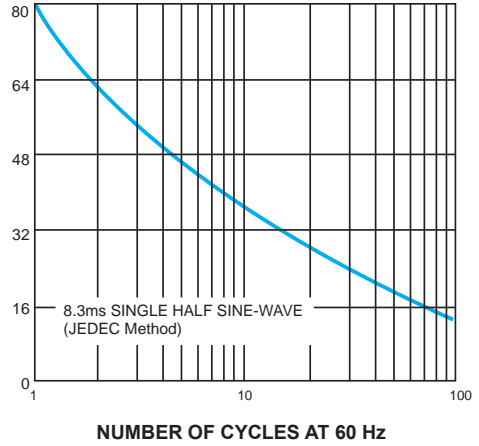
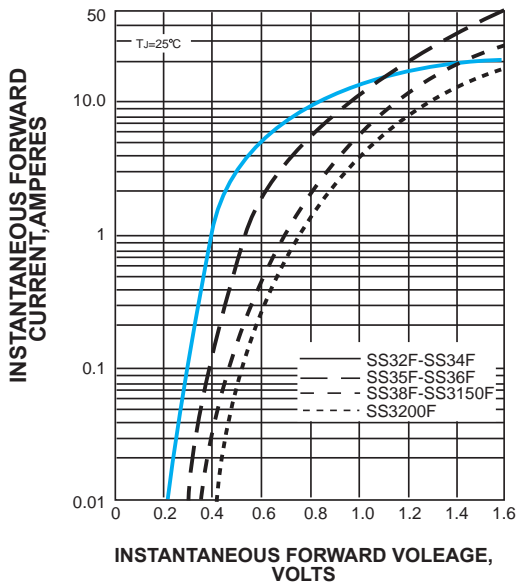

FIG. 3-TYPICAL INSTANTANEOUS FORWARD CHARACTERISTICS



INSTANTANEOUS REVERSE CURRENT, MILLIAMPERES

FIG. 4-TYPICAL REVERSE CHARACTERISTICS

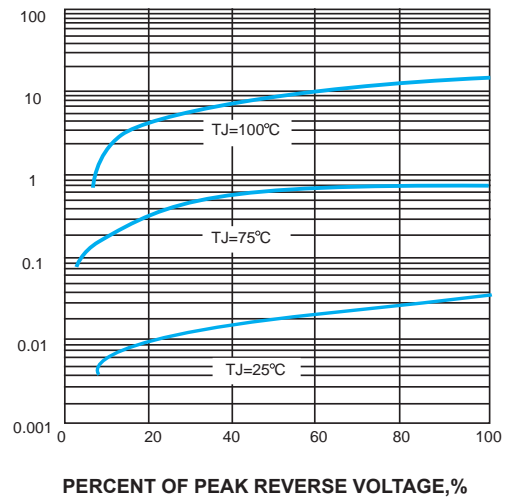
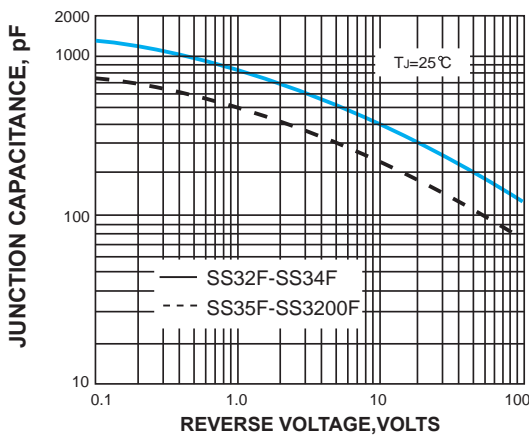
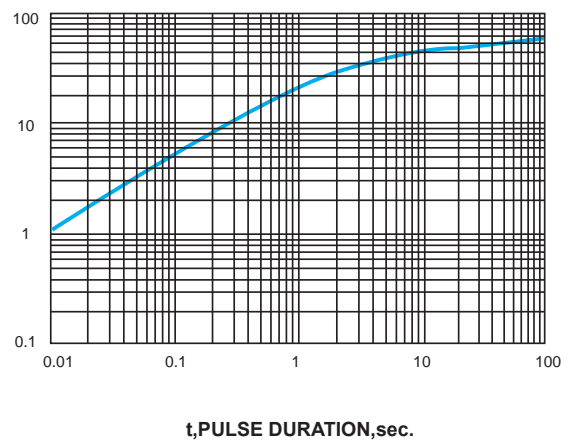

FIG. 5-TYPICAL JUNCTION CAPACITANCE



TRANSIENT THERMAL IMPEDANCE, °C/W

FIG. 6-TYPICAL TRANSIENT THERMAL IMPEDANCE



# SURFACE MOUNT SCHOTTKY BARRIER RECTIFIER SS32F THRU SS3200F

## Packing information

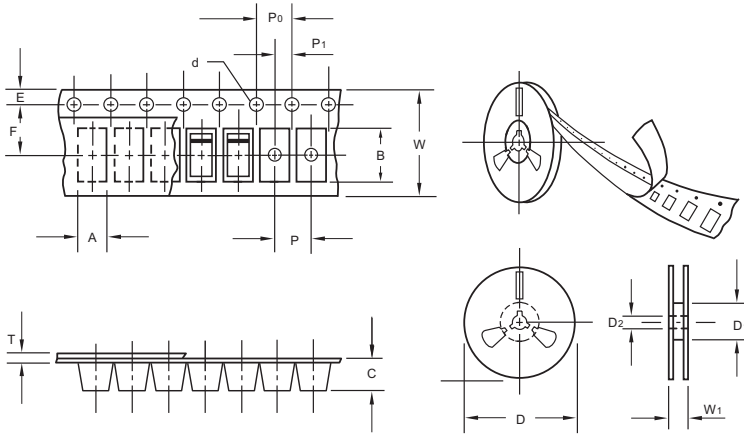

unit:mm

Item	Symbol	Tolerance	SMAF
Carrier width	A	0.1	2.80
Carrier length	B	0.1	4.75
Carrier depth	C	0.1	1.42
Sprocket hole	d	0.05	1.50
7" Reel outside diameter	D	2.0	178.00
7" Reel inner diameter	D1	min	54.40
Feed hole diameter	D2	0.5	13.00
Sprocket hole position	E	0.1	1.75
Punch hole position	F	0.1	5.05
Punch hole pitch	P	0.1	4.00
Sprocket hole pitch	P0	0.1	4.00
Embossment center	P1	0.1	2.00
Overall tape thickness	T	0.1	0.30
Tape width	W	0.3	8.00
Reel width	W1	1.0	12.30

Note: Devices are packed in accordance with EIA standard RS-481-A and specifications listed above.

## Reel packing

PACKAGE	REEL SIZE	REEL (pcs)	COMPONENT SPACING (m/m)	BOX (pcs)	INNER BOX (m/m)	REEL DIA, (m/m)	CARTON SIZE (m/m)	CARTON (pcs)	APPROX. GROSS WEIGHT (kg)
SMAF	7"	3,000	4.0	6,000	210*208*203	178	400*265*400	120,000	10.0

## Suggested Pad Layout

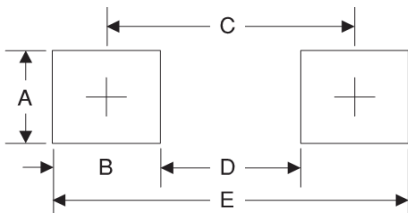

Symbol	Unit (mm)	Unit (inch)
A	1.8	0.071
B	1.6	0.063
C	3.8	0.150
D	2.2	0.087
E	5.4	0.213